

ASSEMBLY INSTRUCTIONS

DESCRIPTION: SHERPA BED WITH SPEAKER
ITEM: 9010 - Q-BED

- Caution:** Please read instructions thoroughly before unpacking assembly parts. Sharp, exposed staple tips can cause injury, therefore, for your protection, please remove any exposed staple used in packing.
1. We recommend that you should assemble this product with the assistance of another person; this will make assembly easier, and will help to eliminate damage to the product or injury to persons during assembly.
 2. Be sure to check all packing materials carefully for small parts that may have come loose inside the carton during shipment.
 3. Please do not over tighten screws or bolts until the assembly is completed.
 4. Please put all parts on a non-abrasive floor before assembly, and follow the assembly steps to assemble your newly purchased product correctly and efficiently.

TOOLS REQUIRED (Not provided)

PHILLIPS SCREWDRIVER



HARDWARE LIST :

No.	Description	Sketch	Size	Quantity
A	Bolt		Ø $\frac{5}{8}$ " x 60mm	8PCS
B	Bolt		Ø $\frac{5}{8}$ " x 45mm	8PCS
C	Bolt		Ø $\frac{1}{4}$ " x 20mm	16PCS
D	Bolt		Ø $\frac{1}{4}$ " x 35mm	4PCS
E	Spring Washer		Ø $\frac{5}{16}$ "	16PCS
F	Flat Washer		Ø $\frac{5}{16}$ "	16PCS
G	Spring Washer		Ø $\frac{1}{4}$ "	20PCS
H	Flat Washer		Ø $\frac{1}{4}$ "	20PCS
J	Allen Key		M4	1PC
K	Screw		M4x 35mm	28PCS
L	Metal Hook Left			2PCS
M	Metal Hook Right			2PCS

PART LIST :

(1)	Headboard		1PC
(2)	Headboard Leg		2PCS
(3)	Footboard		1PC
(4)	Side Rail (Cap)		2PCS
(5)	Side Rail (Outer Panel)		2PCS
(6)	Side Rail (Inner Panel)		2PCS
(7)	Side Rail (Bottom Panel)		2PCS
(8)	Slats roll		2Set
(9)	Center Rail		2PCS
(10)	Center Support Leg		4PCS

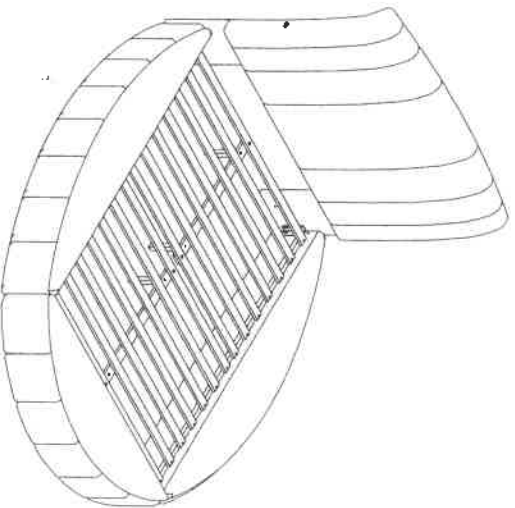





ASSEMBLY INSTRUCTIONS

DESCRIPTION: SHERPA BED WITH SPEAKER

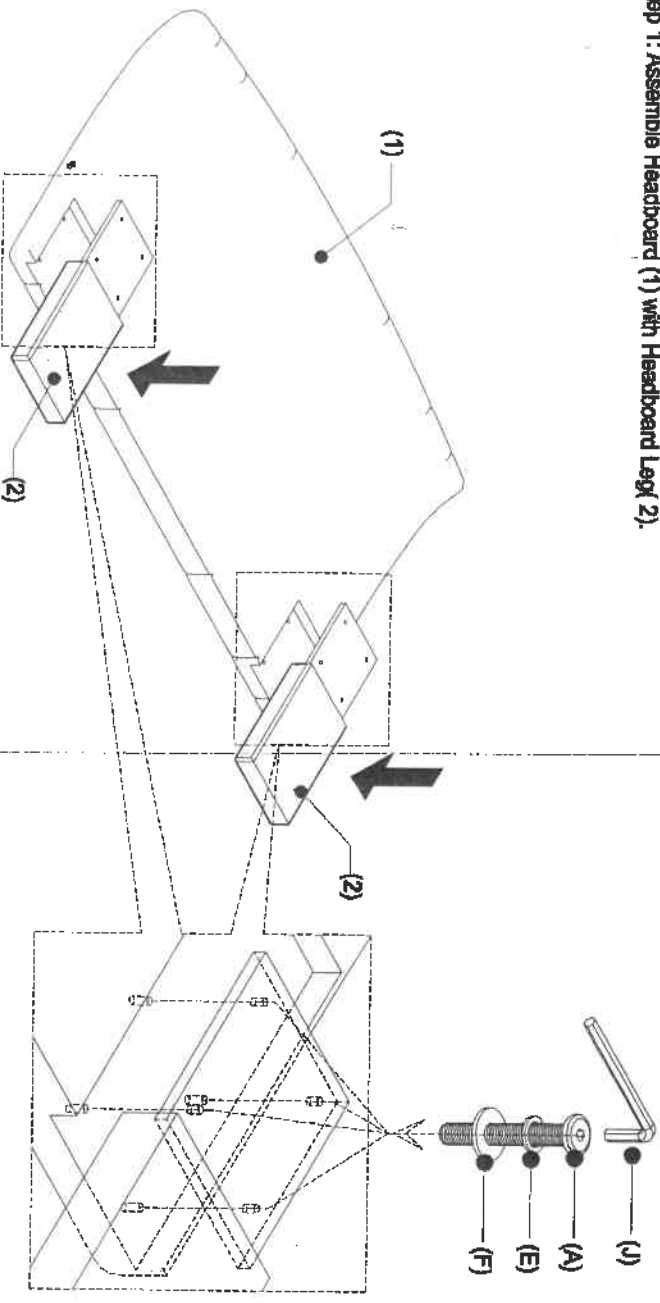
ITEM: 9010 - Q-BED





Step 1: Assemble Headboard (1) with Headboard Leg(2).

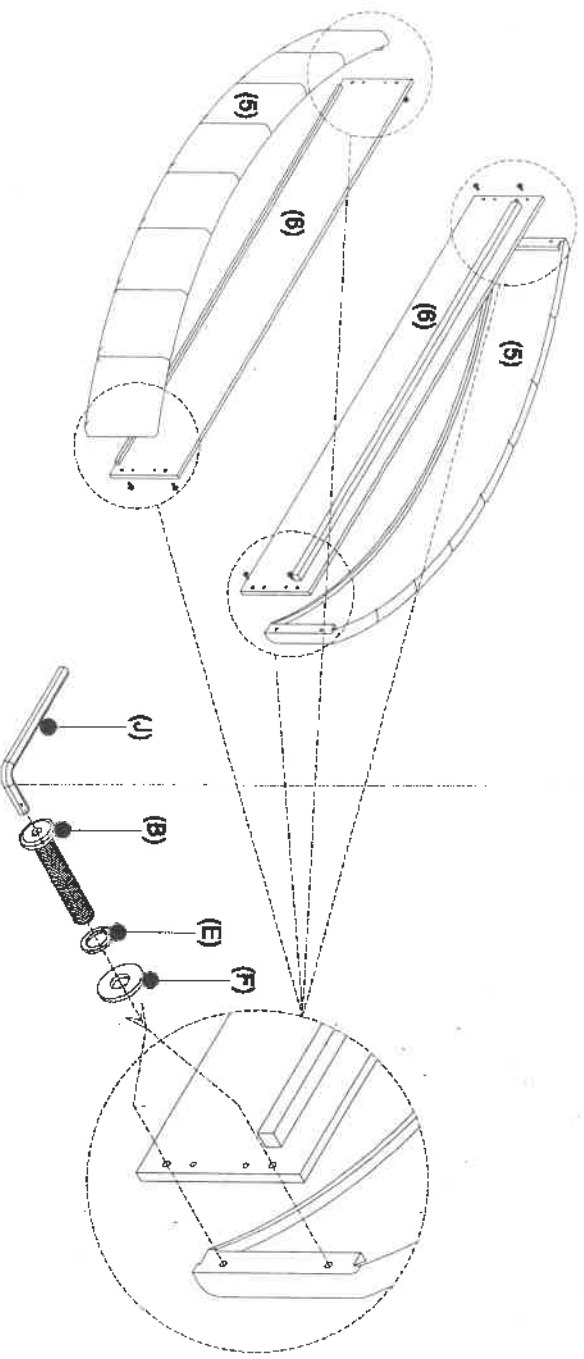

A	Bolt		Ø1/8" x 60mm	8PCS
E	Spring Washer		Ø1/8"	8PCS
F	Flat Washer		Ø1/8"	8PCS
J	Allen Key		M4	1PC

Step 2: Assemble Side Rail (Outer Panel) (5) with Side Rail (Inner Panel) (6).



B	Bolt		Ø1/8" x 45mm	8PCS
E	Spring Washer		Ø1/8"	8PCS
F	Flat Washer		Ø1/8"	8PCS
J	Allen Key		M4	1PC





ASSEMBLY INSTRUCTIONS

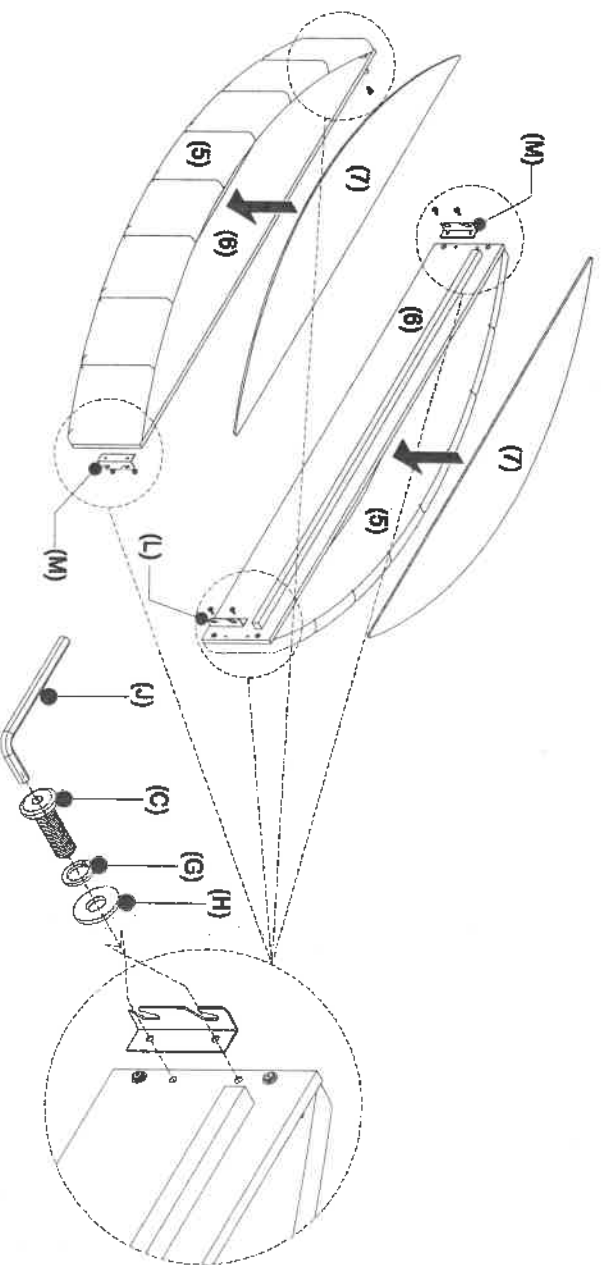

DESCRIPTION: SHERPA BED WITH SPEAKER

ITEM: 9010 - Q-BED

Step 3: Assemble Side rail with Metal Hook Left (L) & Metal Hook Right (M). Place Side rail (Bottom Panel) (7) inside the of Side rail storage.



C	Bolt		Ø1/4" x 20mm	8PCS
G	Spring Washer		Ø1/4"	8PCS
H	Flat Washer		Ø1/4"	8PCS
J	Allen Key		Max 4"L	1PC

L	Metal Hook Left		2PCS
M	Metal Hook Right		2PCS

Step 4: Place Side rail (Cap) (4) on top of the side rail storage.

Side rail(Cap) bottom

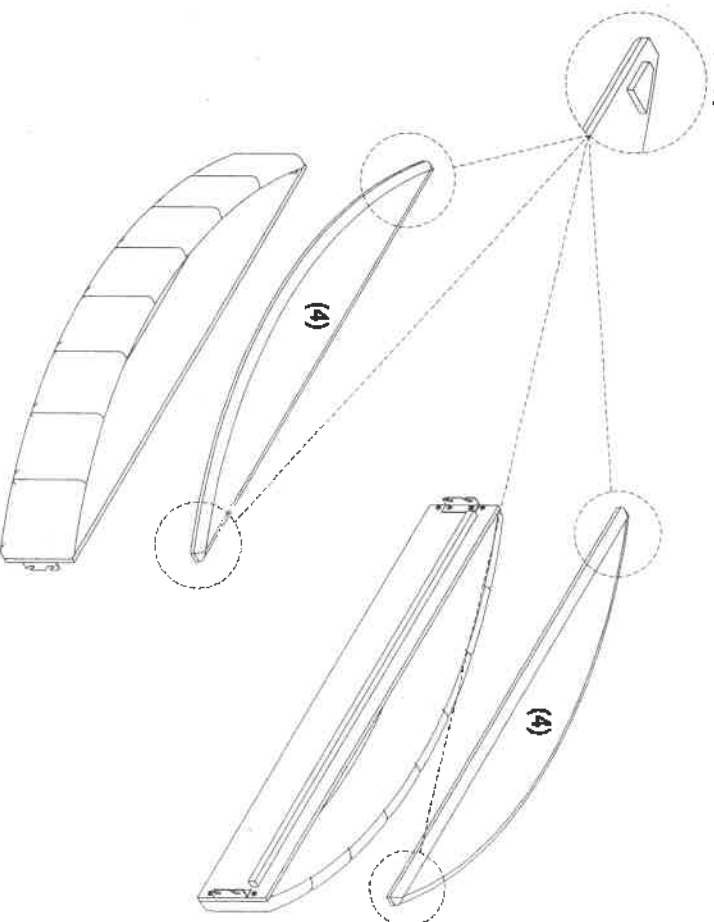

ASSEMBLY INSTRUCTIONS

DESCRIPTION: SHERPA BED WITH SPEAKER
ITEM: 9010 - Q-BED

Step 5: Assemble Center Rail (9) with Slat roll (8) and Center Support Leg (10) with Center Rail (9).

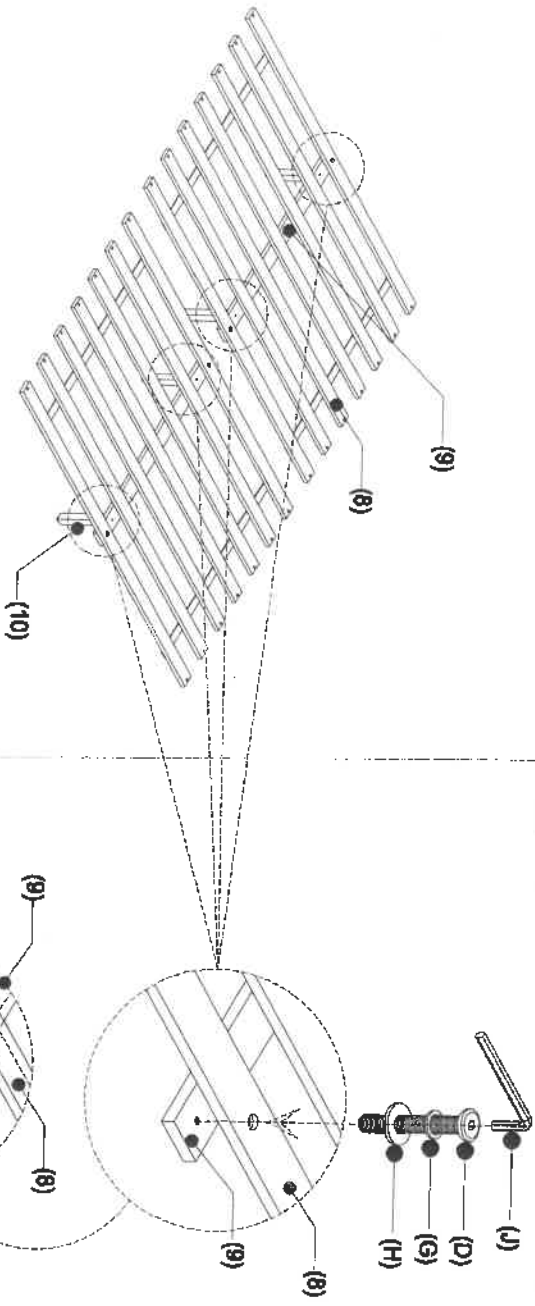

D	Bolt		Ø1/4" x 35mm	4PCS
G	Spring Washer		Ø1/4"	4PCS
H	Flat Washer		Ø1/4"	4PCS
J	Allen Key		M4	1PC

Step 6: Assemble Side Rail with Headboard leg(2) & Footboard(3).

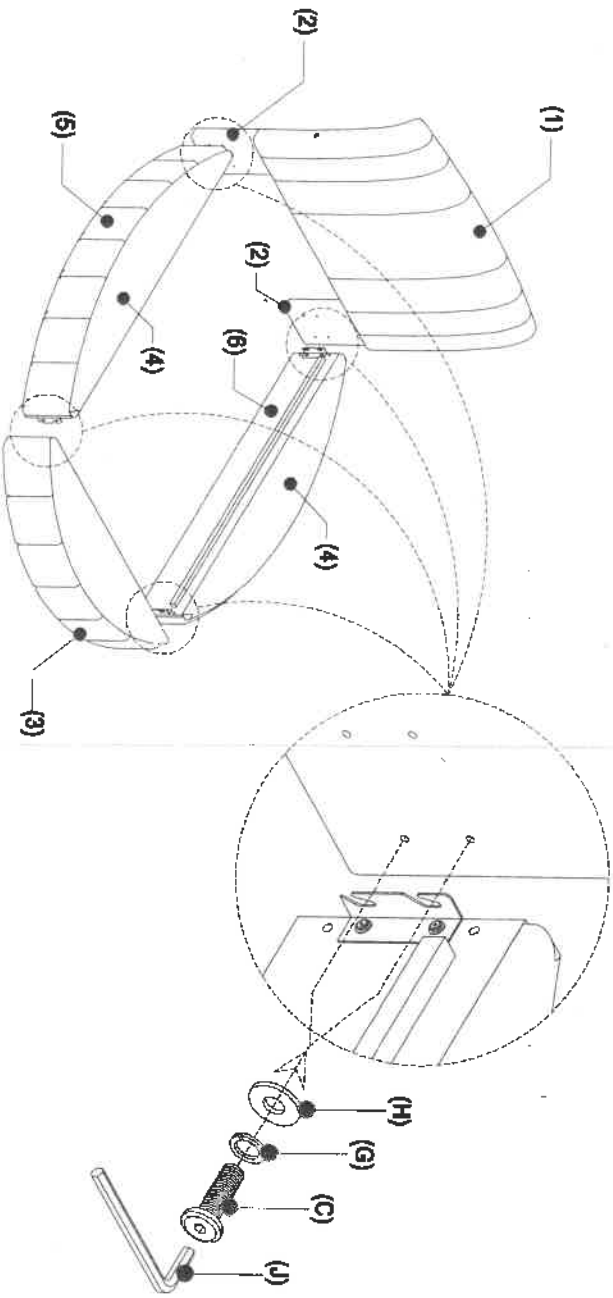

C	Bolt		Ø1/4" x 20mm	8PCS
G	Spring Washer		Ø1/4"	8PCS
H	Flat Washer		Ø1/4"	8PCS
J	Allen Key		MAX 4'L	1PC

MADE IN VIETNAM

PAGE 4 OF 5

ASSEMBLY INSTRUCTIONS

DESCRIPTION: SHERPA BED WITH SPEAKER

ITEM: 9010 - Q-BED

Step 7: Place slats roll (8), Center rails (9), Support leg (10) in the center of the bed. Attach slats roll (8) to support rails.

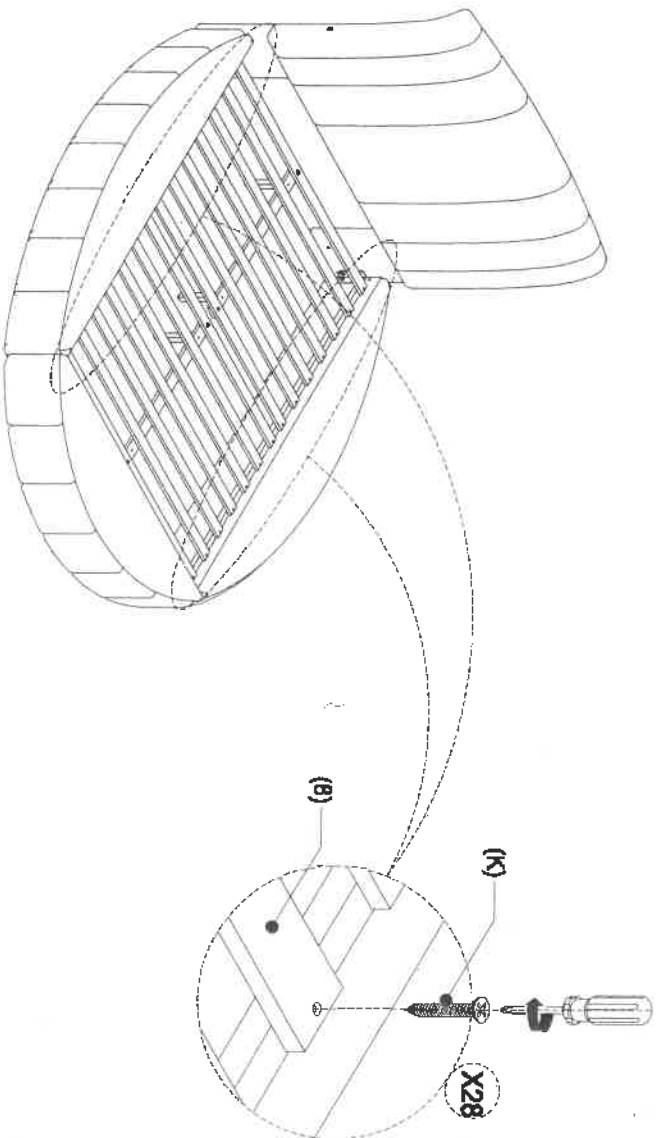

K	Screw		M4x 35mm	28PCS
---	-------	---	----------	-------

Speaker Plug

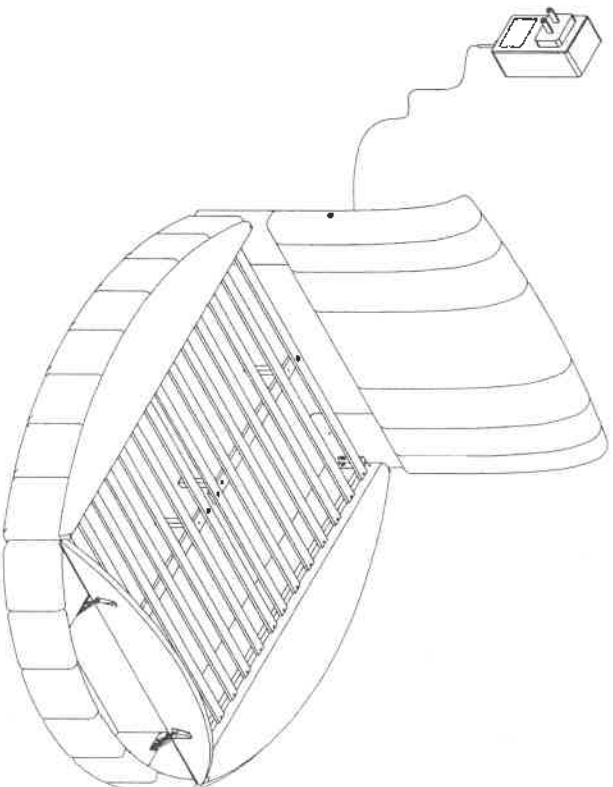

COMPLETE

MADE IN VIETNAM

PAGE 5 OF 5

Audio System

UDM ENTERTAINMENT

Pairing and connecting with a BLUETOOTH device

1. Connect the speaker to an AC outlet.
For the first time after purchase, the speaker indicator flashes quickly in blue and the speaker enters pairing mode automatically. You will hear voice prompt "Bluetooth mode".
2. Perform the pairing procedure on the BLUETOOTH device (mobile/tablet) to detect the speaker. When a list of detected devices appears on the display of the BLUETOOTH device, select "UDM ENTERTAINMENT".
3. Make the BLUETOOTH connection from the BLUETOOTH device, when the BLUETOOTH connection is established, the blue indicator stays on.

Troubleshooting

If the speaker does not function as expected, try the following steps to resolve the issue.

- Make sure the power supply plugged in and check the indicator light of the speaker.
 - If the indicator flashes quickly, proceed to pairing mode.
 - If the indicator stays on, the speakers was connected to one of the devices within 10 meters, please discount the device first, and proceed to pairing mode.
- If the operations above do not work, consult your seller for replacement.

